

**A very perfect circle –  
High precision sealing  
ring with fully balanced  
hot runner system  
injected from the inside.**

## A very perfect circle – High precision sealing ring with fully balanced hot runner system injected from the inside.

WEHA-Gummiwaren-Fabrik Holzberg GmbH & Co. KG, a plastics processing company located in Berlin, Germany and manufacturer of elastomers and Thermoplastics was looking for a mold concept that made it possible to inject a high precision sealing ring from the inside with six injection points to eliminate the unavoidable production of waste in the form of a cold runner rest. It was soon apparent that such an application can be best realized by using hot runner nozzles for side gating from HEITEC Heisskanaltechnik GmbH, because the nozzles are, due to their small size, least likely to interfere with the mold concept.



The problem to be solved:

In the past there were a series of drawbacks evident during the manufacturing of products like the sealing ring, which could not be avoided due to technical reasons. These included the insufficient concentricity, radial run out, cold cracks and the presence of air pockets in the plastic parts. One difficulty that arises from the use of cold runners is that it is almost impossible to influence the filling behavior of the parts. Another problem that often emerges with similar applications is that the air remains inside the cold runner and is forced ahead of the melt until it is pushed through the bores and into the cavities.

All the problems mentioned can more or less successfully be eliminated or at least minimized by optimizing the mold, the process parameters and the technical fine tuning.

The biggest potential for improvement, especially if you consider the economic aspect of the production process, can be found in the waste of material that results in the accumulation of sprue. This large quantity of wasted material is not acceptable for both economic and ecological reasons. In the present case of the high precision sealing ring, the sprue spider, weighing 14g, takes more than twice as much material as the ring itself, which weighs only 6.25g.

### Specifications of the plastic part:

The sealing ring has a diameter of 200mm, a height of 8mm and a wall thickness of 1mm at a shot weight of 6.25g. The tolerances demanded by the customer are very small because the size accuracy has to guarantee the leak tightness and accuracy of location of the follow-up parts. The injection point of the plastic parts should not project beyond the contour because this would affect the functionality of the ring. The junction that cannot be eliminated due to physical reasons should not at all influence the stability of the ring by their notch effect. The material used for the production of the sealing ring is PA with 35% glass fiber.

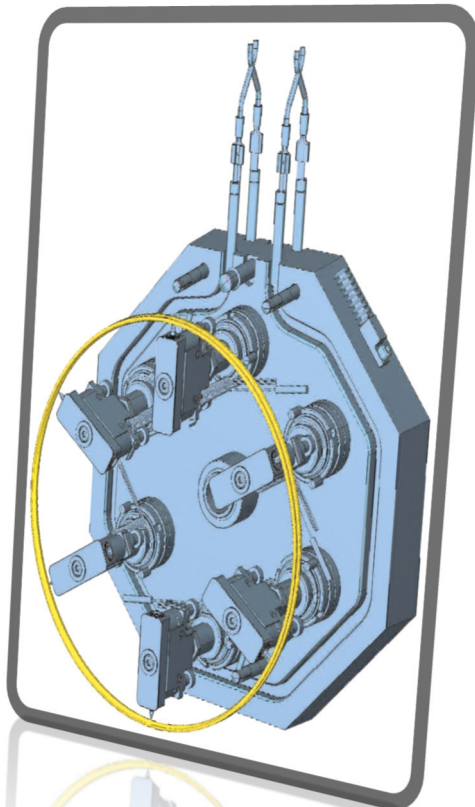

### Mold specifications:

The sealing ring is produced in a one-drop mold. The tool had to be constructed in a way that would minimize the size of the required injection molding machine for the production of the parts. Since the projection space of the ring is relatively small, only a slight uplift pressure is yielded. Slide dampers were used in order to solve the problems resulting from the undercuts in the plastic part.



Advantages resulting from the use of the hot runner system:

A great advantage for the mold design is the small installation space required by

the flat shape of the Star-Line nozzles. In other applications, this advantage can be used for the side gating of plastic parts with only one injection point. Furthermore, the Star-Line nozzles with their various types, that can be used with one up to eight tips for side gating offer a lot of possibilities to the technical product designer and the mold designer, which other nozzles simply cannot. The length of the nozzles, the location of the injection point and the position inside the tool are almost unlimited and that is why HEITEC calls it Freedimensional®. So, the mold designer is finally able to inject the plastic part exactly at the desired point and not only where the mold allows it. In case of the sealing ring, the nozzles of the type 01.076.44.01.L were arranged in a star-like pattern that is reminiscent of star engines from ancient airplanes. Another major advantage of the hot runner system is that the length expansion, especially in the case of very long nozzles, is no longer a problem, because the length expansion is completely compensated for within the system. Therefore, no such problems like moving injection points and elongated holes arise. Another great advantage of the nozzles, in comparison to similar products produced by competitors, is the very precise thermal profile, which enables the customer to process even challenging materials, including those for technical plastics, high temperature materials or filled materials. For this reason, it was no problem to process the Polyamide filled with 35% glass fiber.

Further capabilities:

The principle of the arrangement of the nozzles can, of course not only be used for the production of rings and similar applications, but can also be helpful to realize applications like, for example, the inside injection of cans, pots, boxes, body housings and many more. The sealing ring could have also been injected from the outside with the use of six nozzles, if the plastic part had required this.

Conclusion:

The customer was able to considerably reduce his material demand by approximately 66%, which helped to lower the costs of production massively. Parallel to that, additional duties like the collection and extra handling of the sprue, cease to exist. Not to mention the fact that saving material is quite a win for our environment. WEHA complimented the design solution that was made possible by the use of Star-Line nozzles and the great advantages concerning the production process and the increased productivity. Besides that, they say they are quite impressed by the accuracy of the plastic part, which is absolutely necessary to guarantee the functionality of the sealing ring.

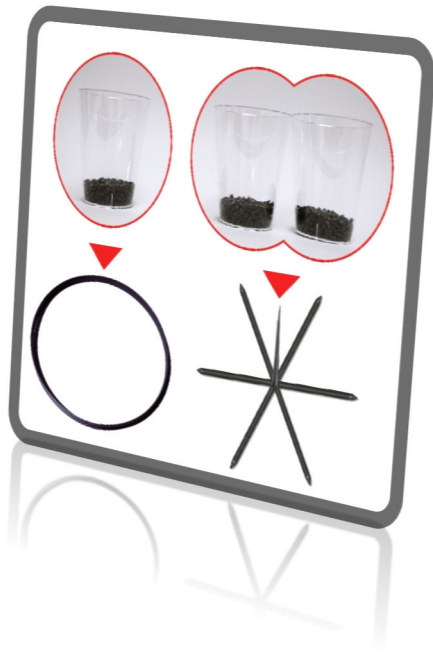

HEITEC Heisskanaltechnik GmbH  
Frankenberger Straße 25  
35099 Burgwald  
Tel.: +49 (06451) 7283-0  
Fax.: +49 (06451) 7283-83

[www.heitec.com](http://www.heitec.com)

Weha-Gummiwaren-Fabrik Holzberg  
GmbH & Co. KG  
Kleinmachnower Weg 9-11,  
14165 Berlin,  
Tel.: +49 30 845 922 54,  
Fax: +49 30 815 10 31

[www.weha-gummi.de](http://www.weha-gummi.de)